

EEL MOTOR DIMENSIONAL OUTLINES:

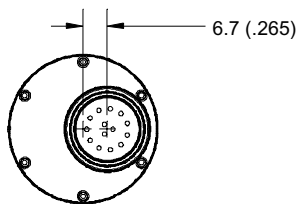
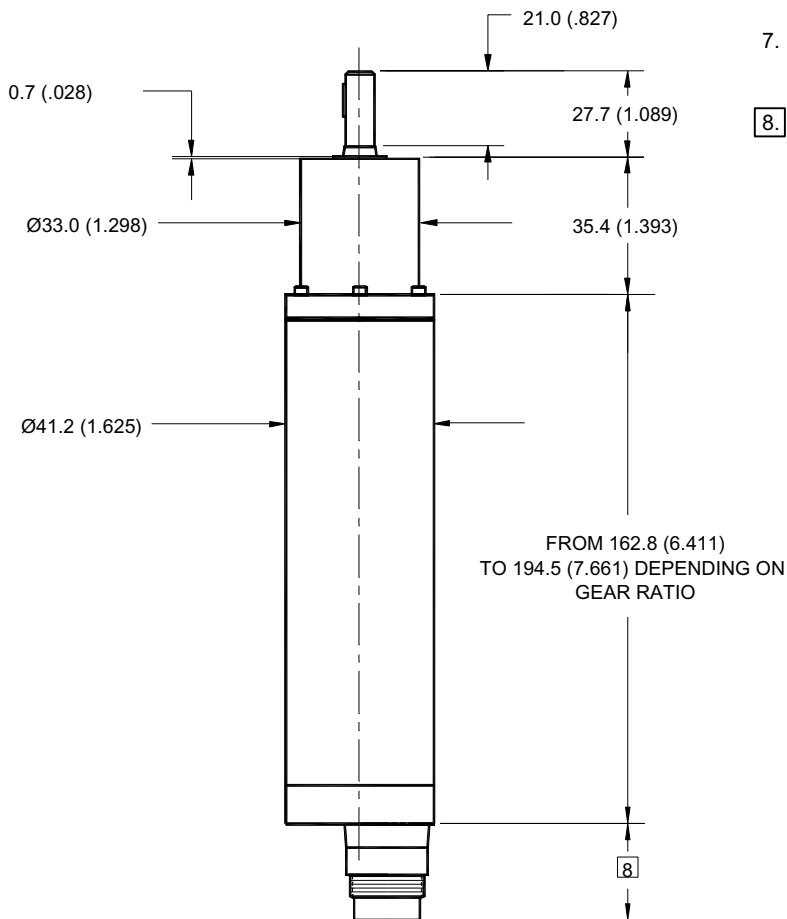
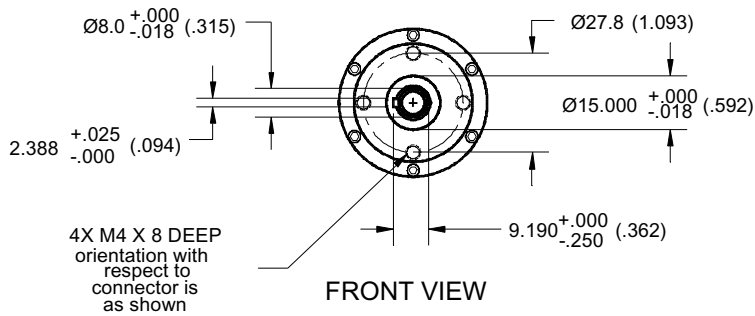

1. Gear ratios are offered in both brush and brushless configurations. A wide variety of gear ratios are available to choose from. Consult manufacturer.
2. 6, 9, 12, 20, 24, and 32 volts are offered for brush type motors. 12, 24, 36, and 48 volts are offered for brushless motors.
3. Continuous output torque range from .18 Nm (25 oz-in) to 4.32 Nm (612 oz-in). Intermittent range from .33 Nm (46 oz-in) to 5.83 Nm (825 oz-in).
4. Safety couplings are an available option. They are set to maximum intermittent output torque.
5. Optical encoders with up to 1000 CPR, magnetic encoders with up to 16 CPR, and resolvers are available. Consult manufacturer for specific application.
6. Tachometers are not available for electronically commutated (brushless) motors.
7. Teflon or polyethylene seal is standard. Other seal materials are available on request. Consult manufacturer.
8. Consult with manufacturer for connector and cabling options.

Dimensions are in mm (in.).

Dimensions with no tolerance indicated are as follows:

For Dimensions:	Tolerance:
Less than or equal to 6 mm	+/- 0.1mm (.0039 in.)
Less than or equal to 30 mm	+/- 0.2mm (.0079 in.)
Less than or equal to 120 mm	+/- 0.3mm (.0118 in.)

**EXTREME
ROBOTICS™**