

MINI EEL MOTOR DIMENSIONAL OUTLINES:

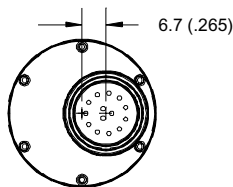
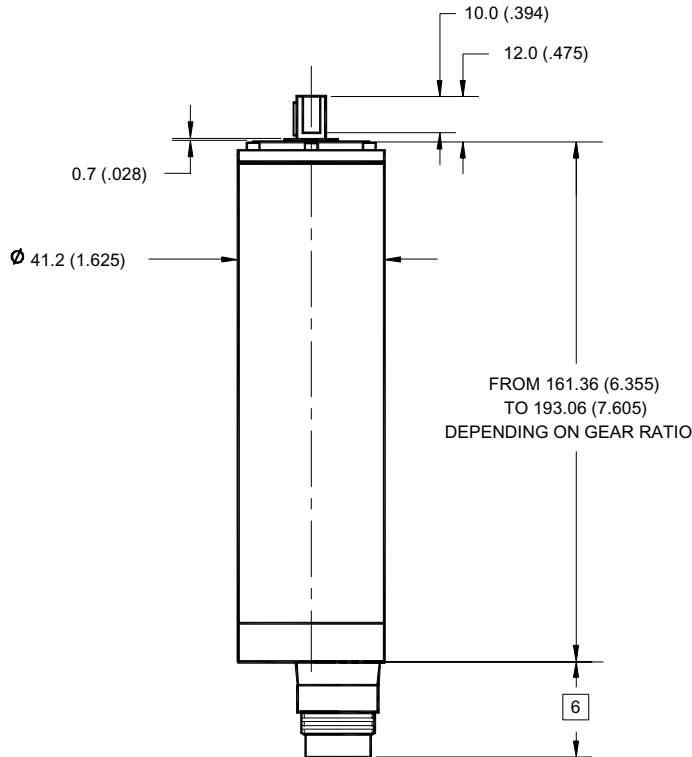
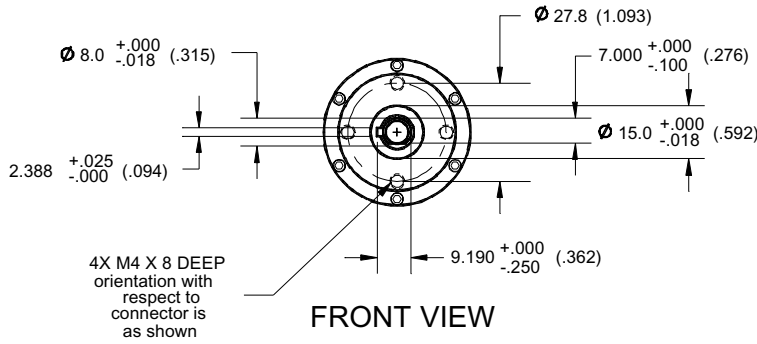

Dimensions are in mm (in.).

Dimensions with no tolerance indicated are as follows:

For Dimensions:	Tolerance:
Less than or equal to 6 mm	+/- 0.1mm (.0039 in.)
Less than or equal to 30 mm	+/- 0.2mm (.0079 in.)
Less than or equal to 120 mm	+/- 0.3mm (.0118 in.)

1. Available voltages are 12, 24, 36, and 48 volts DC.
2. A wide variety of gear ratios to choose from. Consult manufacturer.
3. Optical encoders with up to 1000 CPR, and magnetic encoders with up to 16 CPR, and resolvers are available. Consult manufacturer for specific application.
4. Continuous output torque range from .18 Nm (25 oz-in) to 4.32 Nm (612 oz-in). Intermittent range from .33 Nm (46 oz-in) to 5.83 Nm (825 oz-in).
5. Teflon or polyethylene seal is standard. Other seal materials are available on request. Consult manufacturer.
- 6.** Consult with manufacturer for connector and cabling options.

**EXTREME
ROBOTICS™**