

DESKTOP WINDER SPEC

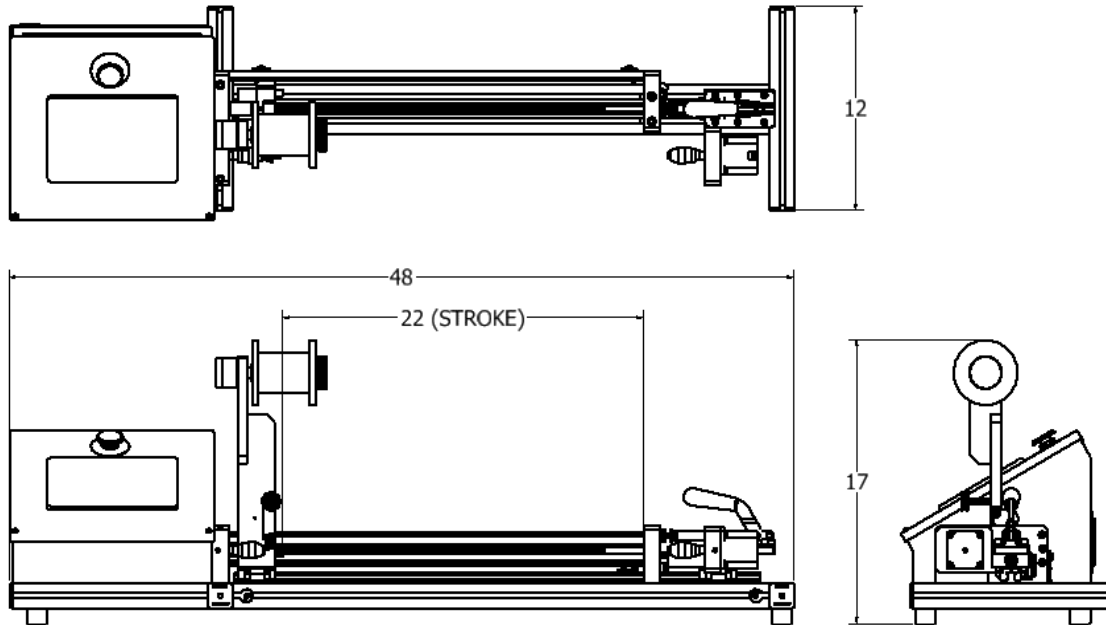

SPECIFICATIONS:

- SPOOL SIZE: DIN 100 Maximum
- INPUT POWER: 120 VAC, single phase with ground, 50/60 Hz.
- WEIGHT: 50 pounds.
- DIMENSIONS: 12 inches wide X 48 inches long X 17 inches tall.
- MANDREL SIZE: .250" diameter Max
- TRAVEL: Adjustable zero to 22" (56cm) with suitable winding accessories
- FILAMENT SIZE: .0004" to .015" round solid or tube, or ribbon, metal or plastic
- WIND SPEED: Up to 1 in/sec Traverse Speed
- FILAMENT TENSION: Adjustable ranges from 5g to 200g max
- MANDREL TENSION: Adjustable to 20 Kg.
- MANDREL LENGTH: Fixed 66 centimeters (26")

FEATURES:

- Winds loose (variable or fixed pitch) coils on a spinning mandrel.
- Right chuck position fixed
- Complex winds possible. CW, CCW, +/- wind direction, Multi-Layer
- Displays of parameter set points
- Servo drives on traverse and both ends of mandrel (no back shaft).
- Alphanumeric color touchscreen display for simple program entry and status displays.
- DIN 80 AND UFW filament Spool size capable
- Optional Traverse Travel lengths (will affect overall length of machine)
- 3-Jaw Chucks with key

Specifications are subject to change without notice