

BENCHTOP WINDER SPEC

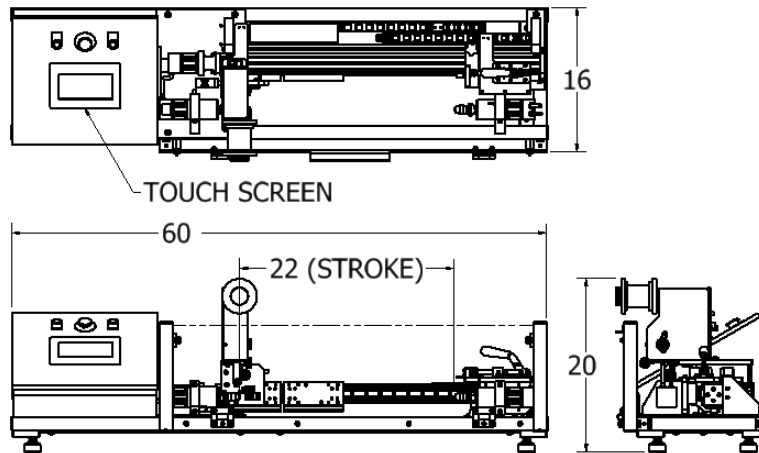

SPECIFICATIONS:

- SPOOL SIZE: DIN 100 Maximum
- INPUT POWER: 120 VAC, single phase with ground, 50/60 Hz.
- WEIGHT: 140 pounds.
- DIMENSIONS: 16 inches wide X 60 inches long X 20 inches tall.
- MANDREL SIZE: .250" diameter Max
- TRAVEL: Adjustable zero to 22" (56cm) with suitable winding accessories – (Standard)
- FILAMENT SIZE: .0004" to .015" round solid or tube, or ribbon, metal or plastic
- WIND SPEED: Up to 50 RPS and 3.9 in/sec Traverse Speed
- FILAMENT TENSION: Adjustable ranges from 5g to 200g max (Standard); Selectable 5g to 80g or 80g – 500g(Optional)
- MANDREL TENSION: Lever Actuated, Screw Adjust
- MANDREL LENGTH: Adjustable from 15 to 66 centimeters (6" to 26")
- COMPLIANCE: Built to CE and NFPA 79 standards

FEATURES:

- Winds loose (variable or fixed pitch) coils on a spinning mandrel.
- Right chuck position can be adjusted to get variable mandrel lengths.
- Mandrel length is part of the recipe setting and travel is limited accordingly.
- Up to 25 process recipes can be stored with up to 20 steps each
- Displays of parameter set points and actual values.
- Filament slack control that maintains tension at all wind speeds.(Optional)
- Brushless servo drives on traverse and both ends of mandrel (no back shaft).
- Alphanumeric color touchscreen display for program entry and status displays.
- Folding Acrylic safety panel
- DIN 80 AND UFW filament Spool size capable
- Optional Chucks: 3 Jaw, Collet

Specifications are subject to change without notice