

BENCHTOP "BELT SERIES" WINDER SPEC

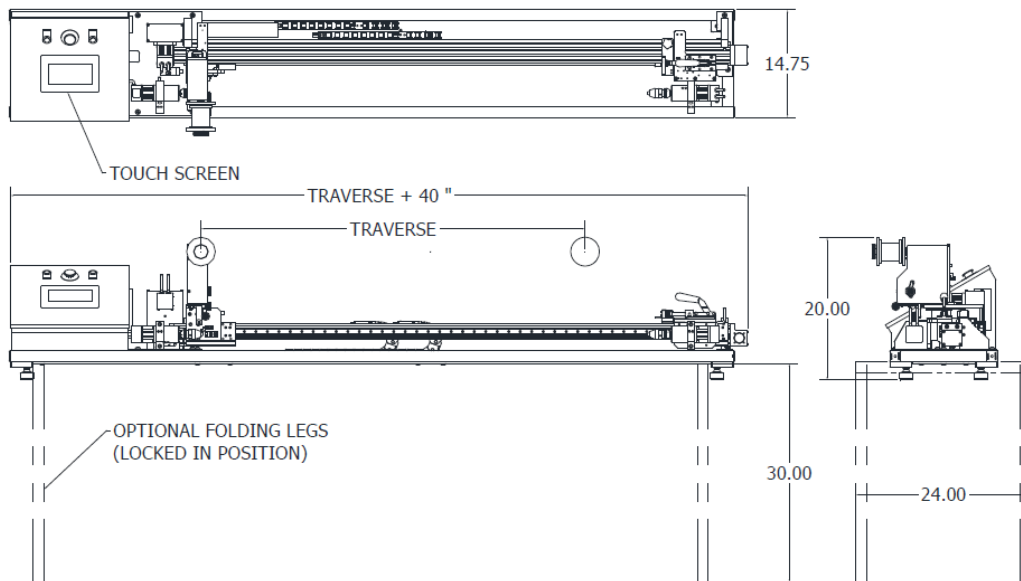

SPECIFICATIONS:

- SPOOL SIZE: DIN 100 Maximum
- INPUT POWER: 120 VAC, single phase with ground, 50/60 Hz.
- WEIGHT: 145 pounds (22" Travel): Add 1 pound per inch there after
- LENGTH: Travel + 40"
- TRAVEL: Adjustable zero to "X Travel" with suitable winding accessories. Max travel 96"
- MANDREL SIZE: .125" diameter Max (.125 Diameter 3-Jaw Chuck) – (Standard)
- MANDREL STRETCH: Accommodates up to .75" Max FILAMENT SIZE: .0004" to .015" round solid or tube, or ribbon, metal or plastic
- WIND SPEED: Up to 50 RPS and 10 in/sec Traverse Speed
- FILAMENT TENSION: Adjustable ranges from 5g to 75g max
- MANDREL TENSION: Manual Lever Actuated, Screw Adjust (Standard); Pneumatic (Optional)
- COMPLIANCE: Built to CE and NFPA 79 standards

FEATURES:

- Winds loose (variable or fixed pitch) coils on a spinning mandrel.
- Right chuck position can be adjusted to get variable mandrel lengths.
- Mandrel length is part of the recipe setting and travel is limited accordingly.
- Up to 25 process recipes can be stored with up to 20 steps each
- Displays of parameter set points and actual values.
- Filament slack control that maintains tension at all wind speeds. (Optional)
- Brushless servo drives on traverse and both ends of mandrel (no back shaft).
- Alphanumeric color touchscreen display for program entry and status displays.
- Folding Acrylic safety panel
- DIN 80 AND UFW filament Spool size capable
- Optional Traverse Travel lengths (will affect overall length of machine)
- Optional Chucks: .250" diameter 3 Jaw, Collet

Specifications are subject to change without notice